

# How to beat restrictions imposed by No-cloning Theorem and Relativity Theory?

Dhananjay P. Mehendale  
Sir Parashurambhau College, Tilak Road, Pune 411030,  
India

## Abstract

We suggest a way to produce any number of clones of an unknown quantum state. We also suggest a way to transmit information from one place to other far away place exactly and almost instantaneously. This paper thus aims to suggest a method to produce “more than one clone” and a method to achieve “instantaneous and exact information transfer”.

**1. Introduction:** Quantum entanglement describes the strong correlation that exists among different parts of composite quantum system [1], [2]. The parts of this composite quantum system may be space-like separated from one another. The exponential speedup that has been seen in some quantum algorithms over their classical counterparts utilizes this totally non-classical and purely quantum phenomenon of entanglement. Entangled quantum states representing composite systems are those states which cannot be expressed as direct product of states for its parts, i.e. entangled quantum states are those states which are not factorable in terms of tensor product of states corresponding to individual parts which when taken together represent the quantum state for entire composite system. Among the 2-qubit states the Bell states are well-known (maximally) entangled states. Bell states are denoted as  $\{|\beta_{00}\rangle, |\beta_{01}\rangle, |\beta_{10}\rangle, |\beta_{11}\rangle\}$  and the standard computational basis states are denoted as  $\{|00\rangle, |01\rangle, |10\rangle, |11\rangle\}$ . Both these sets of states form orthonormal basis so that any 2-qubit state can be represented in terms of them. The Bell basis states and the computational basis states are inter convertible into each other through the following invertible matrix,  $A$ , which is also unitary (i.e.  $A^{-1} = A^+$ , where  $A^+$  is conjugate transpose of  $A$ ).

$$A = \frac{1}{\sqrt{2}} \begin{pmatrix} 1 & 0 & 0 & 1 \\ 0 & 1 & 1 & 0 \\ 1 & 0 & 0 & -1 \\ 0 & 1 & -1 & 0 \end{pmatrix}$$

Thus, the two bases are related through following matrix equation

$$\begin{pmatrix} |\beta_{00}\rangle \\ |\beta_{01}\rangle \\ |\beta_{10}\rangle \\ |\beta_{11}\rangle \end{pmatrix} = A \begin{pmatrix} |00\rangle \\ |01\rangle \\ |10\rangle \\ |11\rangle \end{pmatrix}$$

As an immediate extension we can similarly have orthonormal Bell basis for 3-qubit states. Bell basis for 3-qubit states can be denoted as  $\{|\beta_{000}\rangle, |\beta_{001}\rangle, \dots, |\beta_{111}\rangle\}$  and relates to standard computational basis for 3-qubit states formed by  $\{|000\rangle, |001\rangle, \dots, |111\rangle\}$  through the following matrix equation

$$\begin{pmatrix} |\beta_{000}\rangle \\ |\beta_{001}\rangle \\ |\beta_{010}\rangle \\ |\beta_{011}\rangle \\ |\beta_{100}\rangle \\ |\beta_{101}\rangle \\ |\beta_{110}\rangle \\ |\beta_{111}\rangle \end{pmatrix} = \frac{1}{\sqrt{2}} \begin{pmatrix} 1 & 0 & 0 & 0 & 0 & 0 & 0 & 1 \\ 0 & 1 & 0 & 0 & 0 & 0 & 1 & 0 \\ 0 & 0 & 1 & 0 & 0 & 1 & 0 & 0 \\ 0 & 0 & 0 & 1 & 1 & 0 & 0 & 0 \\ 1 & 0 & 0 & 0 & 0 & 0 & 0 & -1 \\ 0 & 1 & 0 & 0 & 0 & 0 & -1 & 0 \\ 0 & 0 & 1 & 0 & 0 & -1 & 0 & 0 \\ 0 & 0 & 0 & 1 & -1 & 0 & 0 & 0 \end{pmatrix} \begin{pmatrix} |000\rangle \\ |001\rangle \\ |010\rangle \\ |011\rangle \\ |100\rangle \\ |101\rangle \\ |110\rangle \\ |111\rangle \end{pmatrix}$$

The  $8 \times 8$  matrix on the right hand side in the above equation,  $B$  say, is invertible and in addition unitary too. A further generalization is very much possible by proceeding in the same foot steps of the above cases. We can proceed on the similar lines and define orthonormal Bell basis for n-qubit states, namely,  $\{|\beta_{00\dots 0}\rangle, |\beta_{00\dots 01}\rangle, |\beta_{00\dots 10}\rangle, \dots, |\beta_{11\dots 1}\rangle\}$  and relate it with the corresponding n-qubit computational basis, namely,

$\{|00\dots0\rangle, |00\dots01\rangle, |00\dots10\rangle, \dots, |11\dots1\rangle\}$ . For the sake of simplicity and clarity, instead of writing down the matrix equation relating Bell basis states and computational basis states as written above in the 2-qubit and 3-qubit case for n-qubit case we just state how any general Bell basis state in this case is related to computational basis states as follows:

$$|\beta_{x_1, x_2, \dots, x_n}\rangle = \frac{1}{\sqrt{2}} \left( |0, x_2, x_3, \dots, x_n\rangle + (-1)^{x_1} |1, 1-x_2, \dots, 1-x_n\rangle \right)$$

Using this relation one can easily construct the transformation matrix of size  $2^n \times 2^n$  to express n-qubit Bell basis states in terms of corresponding n-qubit computational basis states. One can further see that as in the previous cases this matrix will be also invertible and unitary.

We give below the quantum circuit to obtain any general n-qubit Bell

state  $|\beta_{x_1, x_2, \dots, x_n}\rangle$  (by operating this quantum circuit) from the computational basis state  $|x_1, x_2, \dots, x_n\rangle$

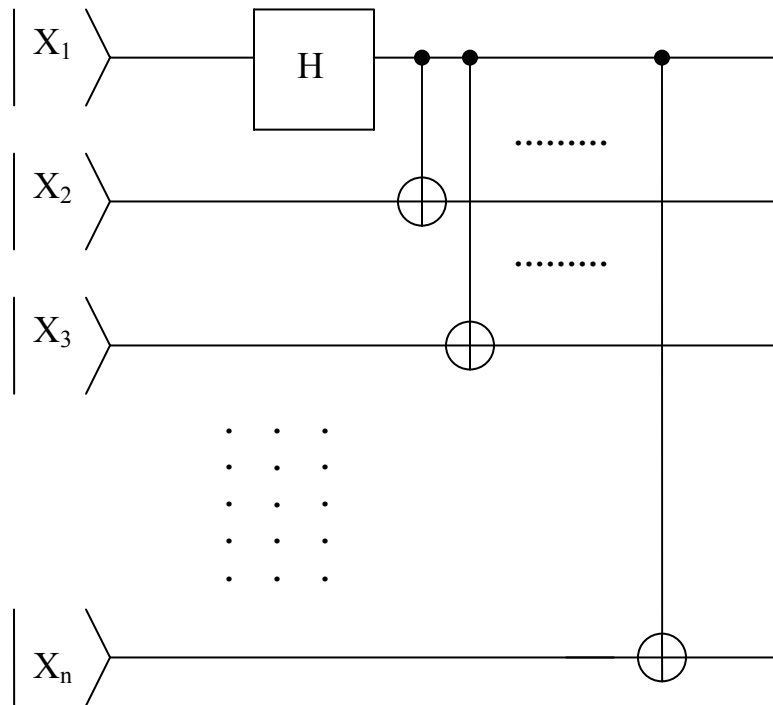

Note that  $|x_1, x_2, \dots, x_n\rangle = |x_1\rangle \otimes |x_2\rangle \otimes \dots \otimes |x_n\rangle$  such that  $x_i \in \{0,1\}$ , for  $i=1,2,\dots;n$ , i.e. a tensor product state, while state  $|\beta_{x_1, x_2, \dots, x_n}\rangle$  on the other hand is not factorable and it is in fact a maximally entangled state.

- 2. Many Clones from an Unknown Quantum State:** We now proceed to achieve our first objective of this paper, namely, to discuss the quantum circuit to produce as many clones as one wants and to suggest an experimental procedure to achieve this task practically for an unknown quantum state,  $|\psi\rangle$  say

$$|\psi\rangle = a|0\rangle + b|1\rangle$$

where  $|a|^2 + |b|^2 = 1$ . In order to achieve this we will make use of the same trick of teleportation used to produce one clone at a place but we will carry out appropriate change in the corresponding quantum circuit to produce more clones at more (different) places. We will develop quantum circuit which will teleport the same unknown quantum state to many different locations, i.e. to many different places where we desire have an exact copy of the quantum state,  $|\psi\rangle$ , described above. In the standard procedure of teleporting the unknown quantum state  $|\psi\rangle$  one requires using given quantum state  $|\psi\rangle$  to be teleported, and a 2-qubit Bell state. Further, one requires making two measurements, one made with respect to given unknown quantum state to be teleported, and the other with respect to particle with Alice. The outcome of these measurements one needs to convey to Bob in order to create an operator to be operated on Bob's state to produce  $|\psi\rangle$  at the location where Bob is situated. This process is generally described in following words: the original state  $|\psi\rangle$  gets destroyed and as a result its clone is produced at Bob's location. This description creates an impression that the unknown state  $|\psi\rangle$  is a kind of conserved quantity and when it is destroyed at

original location then and only then it can appear at new (Bob's) location. Thus, it is impossible to produce more than one clones of the state  $|\psi\rangle$  because it will violate a kind of conservation rule. In actuality, the process of teleportation doesn't imply any kind of movement of original state  $|\psi\rangle$  to new location. In actuality, teleportation is a clever procedure of transforming Bob's particle into state  $|\psi\rangle$ . Bob's particle and Alice's particle are entangled with one another. By allowing Alice's particle in this entangled pair to interact with the given quantum state  $|\psi\rangle$  to be copied and further making measurement with respect to state  $|\psi\rangle$  and Alice's particle leading to finding out two values. These values are fetched to construct the operator to be applied on Bob's state. This operator when operated on Bob's state makes Bob's state to settle as the desired state  $|\psi\rangle$ . Thus, we require to operate Bob's state with an operator to convert it into state  $|\psi\rangle$ , and thus it is Bob's state that gets converted into  $|\psi\rangle$  and not the one that is destroyed in the measurement. In order to construct the operator to be operated on Bob's state to convert it into  $|\psi\rangle$  require results of two measurements these measurements as a side effect cause destruction of original state  $|\psi\rangle$ . When the procedure of teleportation for teleporting  $|\psi\rangle$  from one place to other will be clearly understood the following discussion about teleporting the state  $|\psi\rangle$  to many different desired locations can be hoped to make sense. Suppose our aim is to produce  $n$  copies of the unknown state  $|\psi\rangle$ . As a first step we produce, independently of each other and without any knowledge of each other,  $n$ -copies of maximally entangled pairs of particles. We keep one particle from each such maximally entangled pair with **Alice** and keep other particles with different people, say **Bob(1)**, **Bob(2)**, ..., **Bob(n)**, located at different locations and unrelated to each other. We aim to produce one clone of  $|\psi\rangle$ , at each of the locations where **Bob(1)**, **Bob(2)**, ..., **Bob(n)** are situated. We associate labels with the particles as follows. We assign label  $\{1\}$  with quantum state  $|\psi\rangle$  to be teleported. We label the entangled pairs with label pairs  $\{2, 3\}$ ,  $\{4, 5\}$ , .....,  $\{2k, 2k+1\}$ , .....,  $\{2n, 2n+1\}$ . Particles with labels  $\{2, 4, 6, \dots,$

$2k, \dots, 2n\}$  are in possession of Alice while particles with labels  $\{3, 5, \dots, 2k+1, \dots, 2n+1\}$  are kept respectively with **Bob(1), Bob(2), ..., Bob(k), ..., Bob(n)**, stationed at different locations.

In order to achieve the task of producing  $n$  clones of  $|\psi\rangle$  we will use the following quantum circuit. We will make in total  $(n+1)$  measurements and using the outcomes of these measurements we will construct  $n$  operators to be operated on states of particles in possession of **Bob(1), Bob(2), ..., Bob(k), ..., Bob(n)** to get there **an exact copy** of state  $|\psi\rangle$ .

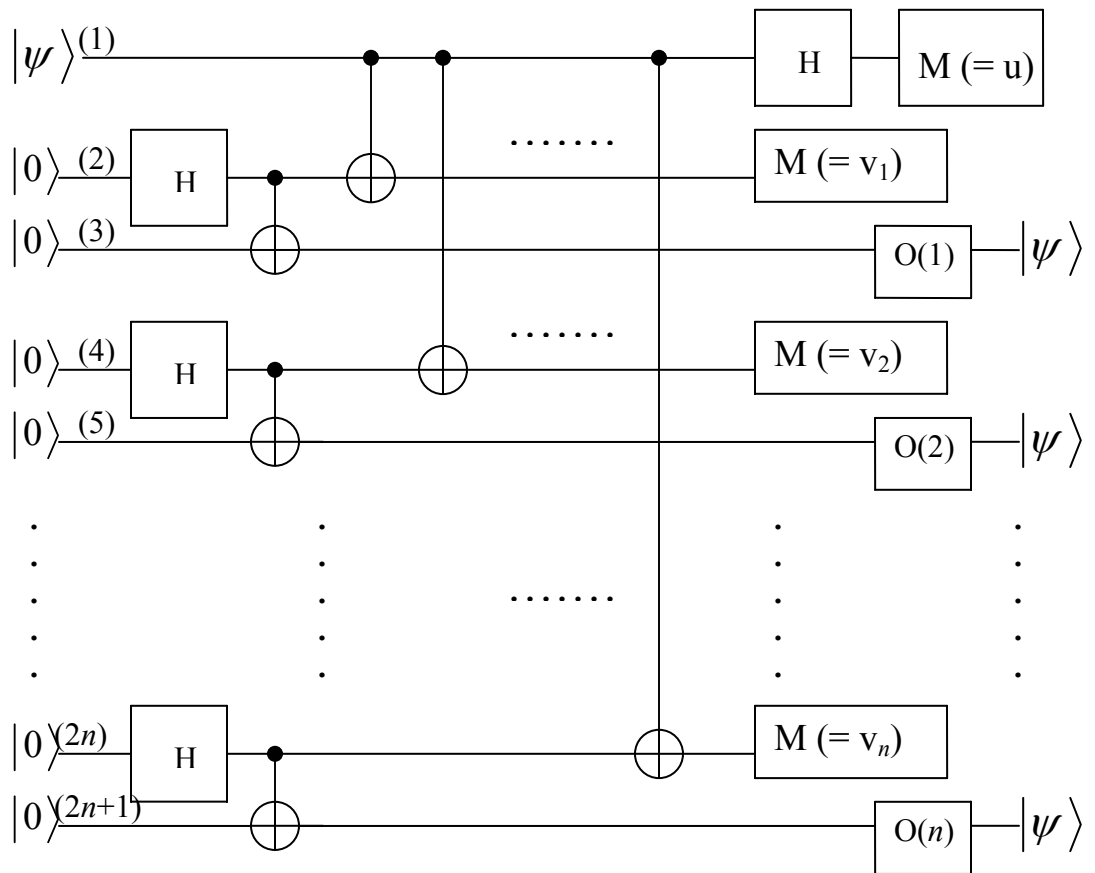

In the above quantum circuit symbols have their usual meaning. For the sake of clarity we think it right to say a few words of explanation: Note that

(i) Symbol H inside a square represents Hadamard gate.

- (ii) Symbol between two data lines made up of a dark dot joined by a vertical line with a circle joined at the end of this vertical line containing plus symbol represents controlled-NOT gate (or, CNOT gate).
- (iii) Symbol M inside a square represents measurement and the result (value) of this measurement is written in front of equality-sign kept inside an open bracket in front of the symbol M.
- (iv) Symbols  $O(1), O(2), \dots, O(k), \dots, O(n)$  represent the operators defined by the following equation

$$O(k) = Z^u X^{v_k}$$

where symbols  $Z$  and  $X$  represent Pauli operators (we operate  $X$  first and then  $Z$ ), and  $u$  and  $v_k$  are values  $\{0 \text{ or } 1\}$  that we get through measurements as shown in the above given quantum circuit.

- (v) Thus, the for any entangled pair, say Alice and Bob( $k$ ), initially there will be state  $|\psi\rangle_1 \otimes |\beta_{00}\rangle_{2k,2k+1}$

Note that

$$\begin{aligned} |\psi\rangle_1 \otimes |\beta_{00}\rangle_{2k,2k+1} &= \left[ \frac{a}{\sqrt{2}} (|000\rangle + |011\rangle) + \frac{b}{\sqrt{2}} (|100\rangle + |111\rangle) \right]_{1,2k,2k+1} \\ &= \frac{1}{\sqrt{2}} \left[ |00\rangle a|0\rangle + |01\rangle a|1\rangle + |10\rangle b|0\rangle + |11\rangle b|1\rangle \right]_{1,2k,2k+1} \end{aligned}$$

Now, we use the relationship between Bell basis and computational basis for 2-qubit state and express each of the 2-qubit computational basis state in the above expression in terms of 2-qubit Bell basis states. Thus, the above expression will become

$$\begin{aligned} &= \frac{1}{2} \left[ (|\beta_{00}\rangle + |\beta_{10}\rangle) a|0\rangle + (|\beta_{01}\rangle + |\beta_{11}\rangle) a|1\rangle + (|\beta_{01}\rangle - |\beta_{11}\rangle) b|0\rangle + (|\beta_{00}\rangle - |\beta_{10}\rangle) b|1\rangle \right]_{1,2k,2k+1} \\ &= \frac{1}{2} \left[ |\beta_{00}\rangle (a|0\rangle + b|1\rangle) + |\beta_{10}\rangle (a|0\rangle - b|1\rangle) + |\beta_{01}\rangle (a|1\rangle + b|0\rangle) + |\beta_{11}\rangle (a|1\rangle - b|0\rangle) \right]_{1,2k,2k+1} \end{aligned}$$

It is clear from this last expression that depending on the values of  $u$  and  $v_k$  operator  $O(k) = Z^u X^{v_k}$  will perform the appropriate action and a copy (exact clone) of  $|\psi\rangle$  will be produced at the location of Bob( $k$ ) for every  $k = 1, 2, \dots, n$ . What actions are carried out depending upon the

values of  $u$  and  $v_k$  by the operator  $O(k) = Z^u X^{v_k}$  can be understood by following table:

Possibilities	$u$	$v_k$	Action1	Action2
1	0	0	Nil	Nil
2	1	0	Change -ve sign to +ve	Nil
3	0	0	Nil	Swap Coefficients (a, b)
4	1	1	Change -ve sign to +ve	Swap Coefficients (a, b)

Note that although the value of  $u$  reaching the different locations where Bob(1), Bob(2), ..., Bob( $k$ ),..., Bob( $n$ ) are situated will be some same value, (0 or 1), the values of  $v_k$ ,  $k = 1, 2, \dots, n$ , could be different for different locations and so the operators,  $O(k) = Z^u X^{v_k}$ , to be operated could be different for Bob(1), Bob(2), ..., Bob( $k$ ),..., Bob( $n$ ) that are to be operated to retrieve the same  $|\psi\rangle$  at all these locations.

**A Simple Experiment for getting Two Clones:** We suggest following simple experiment to get simultaneously two copies of message photon, one arriving at position of Bob(1), and the other at position of Bob(2).

We suggest to conduct the experiment in following steps:

1. We have one message photon to be sent along x- direction.
2. We have two entangled pairs of photons, with one pair shared between Alice and Bob(1) while other pair shared between Alice and Bob(2).
3. We choose and fix a right handed co-ordinate frame.
4. We fix three beam splitters, one to receive photon of Bob(1) arriving along y+ direction and other of Bob(2) arriving along z+ direction, so that the arrived photons upon striking these beam splitters will continue to move along y+ and z+ direction or perpendicularly towards appropriately fixed detectors.
5. The third beam splitter is fixed parallel to (111)- plane near origin to receive three photons arriving simultaneously: Alice's



first photon arriving along y- direction which is entangled with photon of Bob(1), Alice's second photon arriving along z- direction which is entangled with photon of Bob(2), and message photon arriving along x- direction.

6. Suppose all these three photons will arrive at beam splitter fixed parallel to (111)- plane near origin simultaneously and move towards appropriately fixed different detectors in indistinguishable ways. Thus, Alice's two photons get entangled with this message photon.

**Analysis:** Alice's two photons must have polarization states which are opposite to polarization state of message photon as they move towards different detectors. Further, Alice's first photon entangled with Bob(1) and Alice's second photon entangled with Bob(2) had opposite polarizations, therefore, message photon must have same polarization as photons of Bob(1) as well as Bob(2). Therefore, photons reaching Bob(1) and Bob(2) must be clones of message photon.

### **3. Instantaneous Information Transfer among Too Far Away People:**

We now proceed to achieve our first objective of this paper, namely, exact and instantaneous information transfer. In this section we will see how information can be transmitted or transferred or exchanged among persons who are space-like separated from one another and may be residents of different galaxies. Following Shannon, a modern definition of information is nothing but an ordered sequence of zeroes and ones and to transfer this information present at some one place to any other place, i.e. to transfer reliably this prearranged sequence of zeroes and ones present at one location to any other location, through some communication means is in fact the aim and objective of information transfer technology. Sending this information through channels, more or less noisy, introduces some error and thus in that case information is not transferred with 100 percent accuracy as desired. Several error correcting techniques have been developed to manage the transfer of information much reliably and with minimum possible errors. The other aspect related to information transfer is the speed with which this transfer can be brought in effect. There is another aspect related to information transfer and it is about the highest possible speed with which we can do it. Everybody knows that the upper limit that exists on speed of transmitting information is due to fastest speed of signaling as per relativity theory that exists in nature, namely, the velocity of light.



Let Alice and Bob(1), Bob(2), ..., Bob(k),..., Bob(n) share a maximally entangled state  $|\beta_{000\dots 0}\rangle$ . Let Alice and Bob(1) are neighbors while

$$\begin{aligned} |\psi\rangle \otimes |\beta_{00\dots 0}\rangle &= \frac{1}{\sqrt{2}} [ |00\rangle \otimes a|00\dots 0\rangle + |01\rangle \otimes a|11\dots 1\rangle + |10\rangle \otimes b|00\dots 0\rangle + |11\rangle \otimes b|11\dots 1\rangle ] \\ &= \frac{1}{2} [ |\beta_{00}\rangle (a|00\dots 0\rangle + b|11\dots 1\rangle) + |\beta_{01}\rangle (a|11\dots 1\rangle + b|00\dots 0\rangle) ] \\ &+ \frac{1}{2} [ |\beta_{10}\rangle (a|00\dots 0\rangle - b|11\dots 1\rangle) + |\beta_{11}\rangle (a|11\dots 1\rangle - b|00\dots 0\rangle) ] \end{aligned}$$

So, if the values of measurements (M), namely u and v, are conveyed to Bob(1) and he will operate the (entangled) shared state by operator

$O = Z^u X^v$ , X to be operated first and Z later, then the following shared state, shared among Bob(1), Bob(2), ..., Bob(k),..., Bob(n), will result:

$$|\psi\rangle_{shared} = a|00\dots 0\rangle + b|11\dots 1\rangle$$

Suppose Bob(1) wish to convey some information to Bob(2), Bob(3), ...,etc. and suppose this information is following sequence of numbers:  $\{0, 0, 1, 1, 1, 0, 1, 0, 1, 0, 1, 1, \dots\}$ .

Now, if Bob(1) will carry out conditioned measurement of state

$|\psi\rangle_{shared}$  after a regular interval of time such that b is conditioned to take values  $\{0, 0, 1, 1, 1, 0, 1, 0, 1, 0, 1, 1, \dots\}$  at those times of measurements that arrive after regular interval of time. And further Bob(2), Bob(3), ...,etc. are asked to record their state at those times of measurements of Bob(1) then each one, i.e. Bob(2), Bob(3), ...,etc. will record the following sequence of states:

$$\{|0\rangle, |0\rangle, |1\rangle, |1\rangle, |1\rangle, |0\rangle, |1\rangle, |0\rangle, |1\rangle, |1\rangle, \dots\}.$$

Now, from this sequence of states the easily retrievable information, namely,  $\{0, 0, 1, 1, 1, 0, 1, 0, 1, 0, 1, 1, \dots\}$ , will reach to each one, i.e. Bob(2), Bob(3), ...,etc., both exactly and instantaneously!!!

## References

1. Michael A. Nielsen, Isaac L. Chuang, Quantum Computation and Quantum Information, Cambridge University Press, 2000.
2. Colin P. Williams, Explorations in Quantum Computing, Springer, Springer-Verlag London Limited, 2011.